

**FPU® SYSTEMS OPERATION MANUAL
(INCLUDING REPAIR PARTS & SPECIAL TOOL LIST)
BOH CONTAINERIZED LATRINES
BOH FPU Field Pack-up Units**

**CHAPTER 6
PARTS SUPPORTING INFORMATION**

This page was intentionally left blank

PARTS SUPPORTING INFORMATION**FPU[®] SYSTEMS OPERATION MANUAL
(INCLUDING REPAIR PARTS & SPECIAL TOOL LIST)
BOH CONTAINERIZED LATRINES
BOH FPU Field Pack-up Units****INTRODUCTION TO MAINTENANCE ALLOCATION CHART (MAC)**

INTRODUCTION**The BOH Environmental LLC recommended MAC**

This introduction provides a general explanation of all maintenance and repair functions authorized at various maintenance levels under the standard Army Maintenance System concept.

The MAC (WP 0031 00, Table 1) immediately following this introduction designates overall authority and responsibility for the performance of maintenance functions on the containerized latrine.

The application of the maintenance functions to the containerized latrine shall be consistent with the capacities and capabilities of the designated maintenance levels, which are shown on the MAC in column (4) as:

Unit – includes two sub columns, C (operator/crew) and O (unit) maintenance.

Direct Support – includes an F sub column.

General Support – includes an H sub column.

Depot – includes a D sub column.

Maintenance Functions

Maintenance functions are limited to and defined as follows:

1. **Inspect:** To determine the serviceability of an item by comparing its physical and mechanical characteristics with established standards through examination (e.g., by sight, sound, or feel). This includes scheduled inspections.
2. **Test:** To verify serviceability by measuring the mechanical characteristics of an item and comparing those characteristics with prescribed standards on a scheduled basis, i.e., load testing of lift devices and hydrostatic testing of pressure hoses.
3. **Service:** Operations required periodically to keep an item in proper operating condition; e.g., to clean (includes decontaminate, when required), to preserve, to drain, to paint, or to replenish fuel, lubricants, chemical fluids, or gases.
4. **Adjust:** To maintain or regulate, within prescribed limits, by bringing into proper position, or by setting the operating characteristics to specific parameters.
5. **Align:** To adjust specified variable elements of an item to bring about optimum or desired performance.
6. **Calibrate:** To determine and cause corrections or adjustments to be made on instruments of test, measuring, and diagnostic equipment used in precision measurement. Consists of comparisons of

two instruments, one of which is a certified standard of known accuracy, to detect and adjust any discrepancy in the accuracy of the instrument being compared.

7. Remove/Install: To remove and install the same item when required to perform service or other maintenance functions. Install may be the act of emplacing, seating, or fixing into position a spare, repair part, or module (component or assembly) in a manner to allow the proper functioning of an equipment or system.
8. Replace: To remove an unserviceable item and install a serviceable counterpart in its place. "Replace" is authorized by the MAC and assigned maintenance level is shown as the third position code of the Source, Maintenance and Recoverability (SMR) code.
9. Repair: The application of maintenance services, including fault location/troubleshooting, removal/installation, disassembly/assembly procedures, and maintenance actions to identify troubles and restore serviceability to an item by correcting specific damage, fault, malfunction, or failure in a part, subassembly, module (component or assembly), end item, or system.

NOTE

The following definitions are applicable to the "REPAIR" maintenance functions of Service, Inspect, Test, Adjust, Align, Calibrate, and/or Replace:

Fault location/troubleshooting – The process of investigating and detecting the cause of equipment malfunctioning; the act of isolating a fault within a system or Unit Under Test (UUT).

Disassembly/Assembly – The step-by-step breakdown (taking apart) of a spare/functional group coded item to the level of its least component, that is assigned an SMR code for the level of maintenance under consideration (i.e., identified as maintenance significant).

Actions – Welding, grinding, riveting, straightening, facing, machining, and/or resurfacing.

10. Overhaul: That maintenance effort (service/action) prescribed to restore an item to a completely serviceable/operational condition as required by maintenance standards in appropriate technical publications. Overhaul is normally the highest degree of maintenance performed by the Army. Overhaul does not normally return an item to like new condition.
11. Rebuild: Consists of those services/actions necessary for the restoration of unserviceable equipment to a like-new condition in accordance with original manufacturing standards. Rebuild is the highest degree of materiel maintenance applied to Army equipment. The rebuild operation includes the act of returning to zero those age measurements (e.g., hours/miles) considered in classifying Army equipment/components.

Explanation of Columns in the MAC WP 0031 00

Column (1) – Group Number. Column (1) lists Functional Group Code (FGC) numbers, the purpose of which is to identify maintenance significant components, assemblies, subassemblies, and modules with the Next Higher Assembly (NHA).

Column (2) – Component/Assembly. Column (2) contains the item names of components, assemblies, subassemblies, and modules for which maintenance is authorized.

Column (3) – Maintenance Function. Column (3) lists the functions to be performed on the item listed in column (2). (For a detailed explanation of these functions refer to “Maintenance Functions” outlined above).

Column (4) – Maintenance Level. Column (4) specifies each level of maintenance authorized to perform each function listed in column (3), by indicating work time required (expressed as man-hours in whole hours or decimals) in the appropriate sub column. This work time figure represents the active time required to perform that maintenance function at the indicated level of maintenance. If the number or complexity of the tasks within the listed maintenance function varies at different maintenance levels, appropriate work time figures are to be shown for each level. The work time figure represents the average time required to restore an item (assembly, subassembly, component, module, end item, or system) to a serviceable condition under typical field operating conditions. This time includes preparation time (including any necessary disassembly/assembly time), troubleshooting/fault location time, and quality assurance time in addition to the time required to perform the specific tasks identified for the maintenance functions authorized in the MAC. The symbol designations for the various maintenance levels are as follows:

- **C – Operator or crew maintenance**
- **O– Unit maintenance**
- **F – Direct support maintenance**
- **L – Specialized repair activity (SRA)**
- **H – General support maintenance**
- **D – Depot maintenance**

NOTE

The "L" maintenance level is not included in column (4) of the MAC. Functions to this level of maintenance are identified by a work time figure in the "H" column of column (4), and an associated reference code is used in the REMARKS column (6). This code is keyed to the remarks and the SRA complete repair application is explained there.

Column (5) – Tools and Equipment Reference Code. Column (5) specifies, by code, those common tool sets (not individual tools), common Test, Measurement and Diagnostic Equipment (TMDE), and special tools, special TMDE and special support equipment required to perform the designated function. codes are keyed to the entries in the tools and test equipment table

Column (6) – Remarks Code. When applicable, this column contains a letter code, in alphabetical order, which is keyed to the remarks table entries

END OF WORK PACKAGE

PARTS SUPPORTING INFORMATION

**FPU® SYSTEMS OPERATION MANUAL
(INCLUDING REPAIR PARTS & SPECIAL TOOL LIST)
BOH CONTAINERIZED LATRINES
BOH FPU Field Pack-up Units**

MAINTENANCE ALLOCATION CHART (MAC)

(1)	(2)	(3)	(4)					(5)	(6)
Group Number	Component/Assembly	Maintenance Function	Maintenance Level					Tools and Equipment Ref Code	Remarks
			Unit		Direct Support	General Support	Depot		
			C	O	F	H	D		
01	Latrine Continer	INSPECT	0.1	0.1					
		SERVICE		0.2					
		REPLACE		1					
0101	Latrine Door Assembly	INSPECT	0.1	0.1					
		SERVICE		0.2					
		ALIGN			0.5				
		REPLACE		1					
		REPAIR			1				
02	External Electrical	INSPECT	0.1	0.1					MOS 21R
		SERVICE		0.2					
		ALIGN			0.5				
		REPLACE		1					
		REPAIR			1				
0201	Interior Electrical	INSPECT	0.1	0.1					MOS 21R
		SERVICE		0.2					
		ALIGN			0.5				
		REPLACE		1					
		REPAIR			1				
03	Latrine Interior Components	INSPECT	1	1					
		SERVICE		1					
		REPLACE		1					
		REPAIR			1				

END OF WORK PACKAGE

BOH-PM-01-06
Chapter 6 Rev. 1.03

PARTS SUPPORTING INFORMATION

FPU[®] SYSTEMS OPERATION MANUAL (INCLUDING REPAIR PARTS & SPECIAL TOOL LIST) BOH CONTAINERIZED LATRINES BOH FPU Field Pack-up Units

INTRODUCTION TO REPAIR PARTS & SPECIAL TOOL LIST

INTRODUCTION

SCOPE

This Repair Parts & Special Tools List (RPSTL) lists and authorizes spares and repair parts; special tools; special test, measurement, and diagnostic equipment (TMDE); and other special support equipment required for performance of Operator, Unit, and Direct Support maintenance of the containerized latrine. It authorizes the requisitioning, issue, and disposition of spares, repair parts, and special tools as indicated by the Source, Maintenance, and Recoverability (SMR) codes.

GENERAL

In addition to the Introduction work package, this parts list is divided into the following work packages:

1. **Repair Parts List Work Packages WP 0033 00.** Work packages containing lists of spares and repair parts authorized by this parts list for use in the performance of maintenance. These work packages also include parts which must be removed for replacement of the authorized parts. Parts lists are composed of functional groups in ascending alphanumeric sequence, with the parts in each group listed in ascending figure and item number sequence. Sending units, brackets, filters, and bolts are listed with the component they mount on. Bulk materials are listed by item name in FIG. BULK at the end of the work packages. Repair parts kits are listed separately in their own functional group and work package. Repair parts for reparable special tools are also listed in a separate work package. Items listed are shown on the associated illustrations.
2. **Cross-Reference Indexes Work Packages WP 0034 and WP 0035.** There are two cross-reference indexes work packages in this PARTS LIST : the National Stock Number (NSN) Index work package and the Part Number (P/N) Index work package. The National Stock Number Index work package refers you to the figure and item number. The Part Number Index work package refers you to the figure and item number.

EXPLANATION OF COLUMNS IN THE REPAIR PARTS LIST AND SPECIAL TOOLS LIST WORK PACKAGES

ITEM NO. (Column (1)). Indicates the number used to identify items called out in the illustration.

NSN (Column (3)). The NSN for the item is listed in this column.

CAGEC (Column (4)). The Commercial and Government Entity Code (CAGEC) is a five-digit code which is used to identify the manufacturer, distributor, or Government agency/activity that supplies the item.

PART NUMBER (Column (5)). Indicates the primary number used by the manufacturer (individual, company, firm, corporation, or Government activity), which controls the design and characteristics of the item by means of its engineering drawings, specifications, standards, and inspection requirements to identify an item or range of items.

NOTE

When you use an NSN to requisition an item, the item you receive may have a different P/N from the number listed.

DESCRIPTION AND USABLE ON CODE (UOC)

(Column (5)). This column includes the following information:

The ITEM Assembly Progression (**.Item or Assembly, ..Next Lower Item, ...Next Lower Item**)

1. The federal item name, and when required, a minimum description to identify the item.
2. P/Ns of bulk materials are referenced in this column in the line entry to be manufactured or fabricated.
3. Hardness Critical Item (HCI). A support item that provides the equipment with special protection from electromagnetic pulse (EMP) damage during a nuclear attack.
4. The statement END OF FIGURE appears just below the last item description for a given figure in both the repair parts list and special tools list work packages.

QTY (Column (6)). The QTY (quantity per figure) column indicates the quantity of the item used in the breakout shown on the illustration/figure, which is prepared for a functional group, sub-functional group, or an assembly. A "V" appearing in this column instead of a quantity indicates that the quantity is variable and quantity may change from application to application.

EXPLANATION OF CROSS-REFERENCE INDEXES WORK PACKAGES FORMAT AND COLUMNS.

1. National Stock Number (NSN) Index Work Package.

STOCK NUMBER Column. This column lists the NSN in National Item Identification Number (NIIN) sequence. The NIIN consists of the last nine digits of the NSN.

NSN
(e.g.,5385-01-574-1476)

When using this column to locate an item, ignore the first four digits of the NSN. However, the complete NSN should be used when ordering items by stock number.

FIG. Column. This column lists the number of the figure where the item is identified/located. The figures are in numerical order in the repair parts list and special tools list work packages.

ITEM Column. The item number identifies the item associated with the figure listed in the adjacent FIG. Column. This item is also identified by the NSN listed on the same line.

2. Part Number (P/N) Index Work Package. P/Ns in this index are listed in ascending alphanumeric sequence (vertical arrangement of letter and number combinations which places the first letter or digit of each group in order A through Z, followed by the numbers 0 through 9 and each following letter or digit in like order).

PART NUMBER Column. Indicates the P/N assigned to the item.

FIG. Column. This column lists the number of the figure where the item is identified/located in the repair parts list and special tools list work packages.

ITEM Column. The item number is the number assigned to the item as it appears in the figure referenced in the adjacent figure number column.

SPECIAL INFORMATION

UOC. The UOC appears in the lower left corner of the Description Column heading. Usable On Codes are shown as "UOC: . . ." in the Description Column (justified left) on the first line under the applicable item/nomenclature. None coded items are applicable to all models. Identification of the UOCs used in this parts list are: NOT ASSIGNED YET

Fabrication Instructions. Bulk materiel required to manufacture items are listed in the bulk materiel functional group of this parts list. Part numbers for bulk materiel are also referenced in the Description Column of the line item entry for the item to be manufactured/fabricated. Detailed fabrication instructions for items source-coded to be manufactured or fabricated are found in: Not Applicable.

Index Numbers Column. This index number is a cross-reference between the NSN and P/N index work packages and the materiel list in the repair parts list work package.

HOW TO LOCATE REPAIR PARTS

A. When NSNs or P/Ns Are Not Known.

1. Using the table of contents, determine the assembly group to which the item belongs. This is necessary because figures are prepared for assembly groups and subassembly groups, and lists are divided into the same groups.
2. Find the figure covering the functional group or the sub functional group to which the item belongs.
3. Identify the item on the figure and note the number(s).
4. Look in the repair parts list work packages for the figure and item numbers. The NSNs and part numbers are on the same line as the associated item numbers.

B. When NSN Is Known.

1. If you have the NSN, look in the STOCK NUMBER column of the NSN index work package. The NSN is arranged in NIIN sequence. Note the figure and item number next to the NSN.
2. Turn to the figure and locate the item number. Verify that the item is the one you are looking for.

C. When the P/N Is Known.

1. If you have the P/N and not the NSN, look in the PART NUMBER column of the P/N index work package. Identify the figure and item number.
2. Look up the item on the figure in the applicable repair parts list work package.

ABBREVIATIONS

Abbreviation

AY
KT
AR
GFCI
GFCB

Explanation

ASSEMBLY
KIT
AS REQUIRED
GROUND FAULT CIRCUIT INTERRUPTER
GROUND FAULT CIRCUIT BREAKER

END OF WORK PACKAGE

PARTS SUPPORTING INFORMATION
FPU® SYSTEMS OPERATION MANUAL
(INCLUDING REPAIR PARTS & SPECIAL TOOL LIST)
BOH CONTAINERIZED LATRINES
BOH FPU Field Pack-up Units
BOH CONTAINERIZED LATRINE REPAIR PARTS LIST



CONTAINERIZED LATRINE

FIGURES 01 Through 07

CONTAINERIZED LATRINE



FIGURE 01 CONTAINERIZED LATRINE

(1) ITEM NO.	(2) NSN	(3) CAGEC	(4) PART NUMBER	(5) DESCRIPTION AND USABLE ON CODE (UOC)	(6) QTY
				GROUP 01 FIGURE 01 CONTAINERIZED LATRINE	
1	8145-01-606-2837	1NSG3	99000455-UG	.CONTAINERIZED LATRINE GREEN	1
1	8145-01-606-2687	1NSG3	99000455-UT	.CONTAINERIZED LATRINE TAN	1
END OF FIGURE 01					

LATRINE DOOR ASSEMBLY

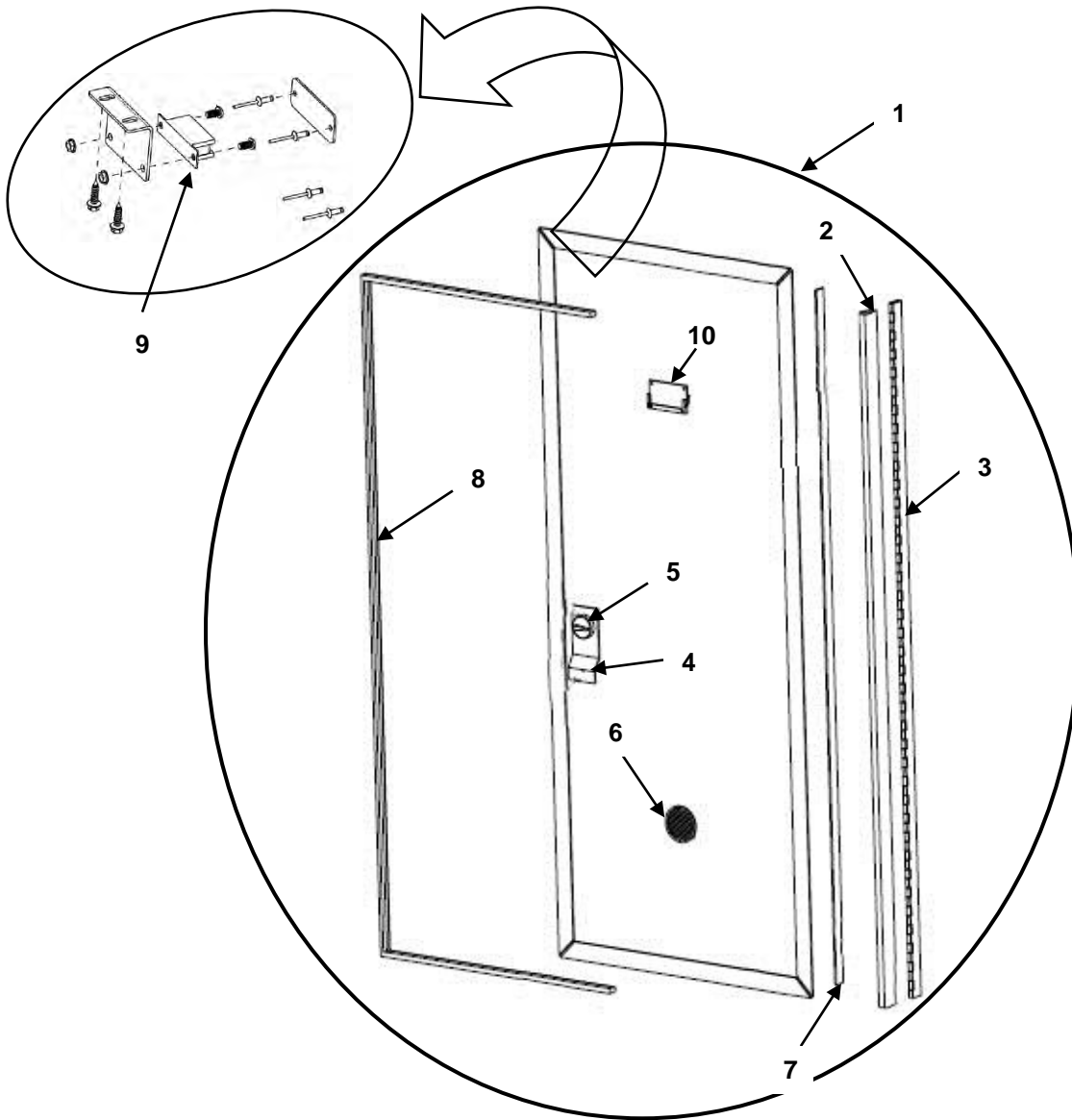

FIGURE 02 LATRINE DOOR ASSEMBLY

(1) ITEM NO.	(2) NSN	(3) CAGEC	(4) PART NUMBER	(5) DESCRIPTION AND USABLE ON CODE (UOC)	(6) QTY
				GROUP 0101 FIGURE 02 DOOR ASSEMBLY	
1	NOT ASSIGNED	1NSG3	15988500-001	..Door Assembly Complete AY Green	6
2	NOT ASSIGNED	1NSG3	83161805	..Vinyl Hinge Strip 5 ft	1
3	NOT ASSIGNED	1NSG3	15988502-001	..Hinge Kit Green	1
4	NOT ASSIGNED	1NSG3	15988506	..Door Pull Int. /Ex. Kit	1
5	NOT ASSIGNED	1NSG3	03060003	..Door Dead Bolt Assembly	1
6	NOT ASSIGNED	1NSG3	15988507	..Vent Louvered 5"	1
7	NOT ASSIGNED	1NSG3	15988331	..Hinge Gasket	1
8	NOT ASSIGNED	1NSG3	83020101	..Door Gasket w/Adhesive 12 ft	1
9	NOT ASSIGNED	1NSG3	15988955	..Magnetic Door Latch Assembly	1
10	NOT ASSIGNED	1NSG3	15988508	..Label Holder Kit	1
1	NOT ASSIGNED	1NSG3	15988500-002	..Door Assembly Complete AY Tan	6
2	NOT ASSIGNED	1NSG3	83161805	..Vinyl Hinge Strip 5 ft	1
3	NOT ASSIGNED	1NSG3	15988502-002	..Hinge Kit Tan	1
4	NOT ASSIGNED	1NSG3	15988506	..Door Pull Int. /Ex. Kit	1
5	NOT ASSIGNED	1NSG3	03060003	..Door Dead Bolt Assembly	1
6	NOT ASSIGNED	1NSG3	15988507	..Vent Louvered 5"	1
7	NOT ASSIGNED	1NSG3	15988331	..Hinge Gasket	1
8	NOT ASSIGNED	1NSG3	83020101	..Door Gasket w/Adhesive 12 ft	1
9	NOT ASSIGNED	1NSG3	15988955	..Magnetic Door Latch Assembly	1
10	NOT ASSIGNED	1NSG3	15988508	..Label Holder Kit	1
END OF FIGURE 02					

EXTERNAL WATER and WASTE CAPS

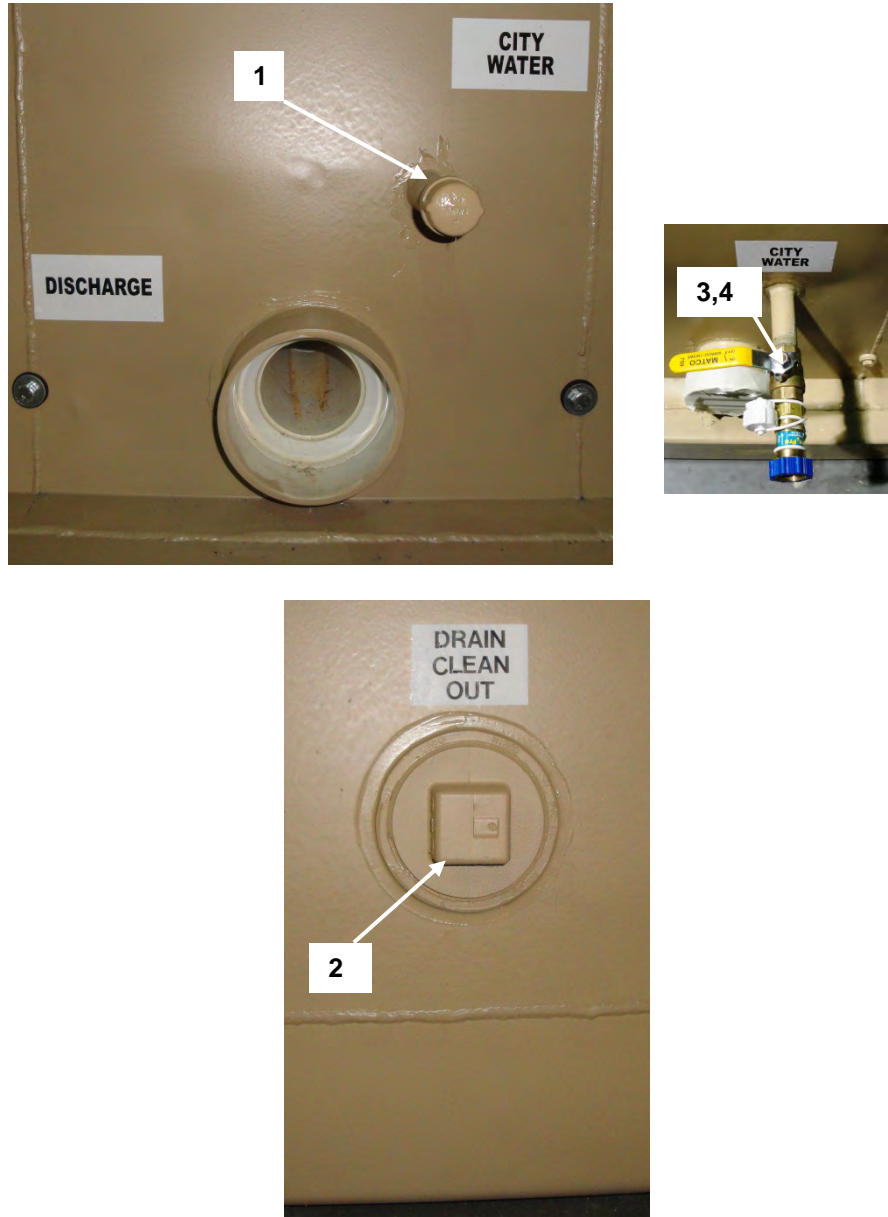

FIGURE 03 EXTERNAL WATER and WASTE CAPS

(1) ITEM NO.	(2) NSN	(3) CAGEC	(4) PART NUMBER	(5) DESCRIPTION AND USABLE ON CODE (UOC)	(6) QTY
				GROUP 0102 FIGURE 03 EXTERNAL WATER AND WASTE CAPS	
1	NOT ASSIGNED	1NSG3	86040412-001	.Water Supply Cap Green	1
2	NOT ASSIGNED	1NSG3	85050448A-001	.Clean Out Cap Green	1
3	NOT ASSIGNED	1NSG3	87060011	.City Water Shutoff Valve AY	1
4	NOT ASSIGNED	1NSG3	38092011	..Check Valve	1
1	NOT ASSIGNED	1NSG3	86040412-002	.Water Supply Cap Tan	1
2	NOT ASSIGNED	1NSG3	85050448A-002	.Clean out Cap Tan	1
3	NOT ASSIGNED	1NSG3	87060011	.City Water Shutoff Valve Ay	1
4	NOT ASSIGNED	1NSG3	38092011	..Check Valve	1
END OF FIGURE 03					

CONTAINERIZED LATRINE EXTERNAL ELECTRICAL

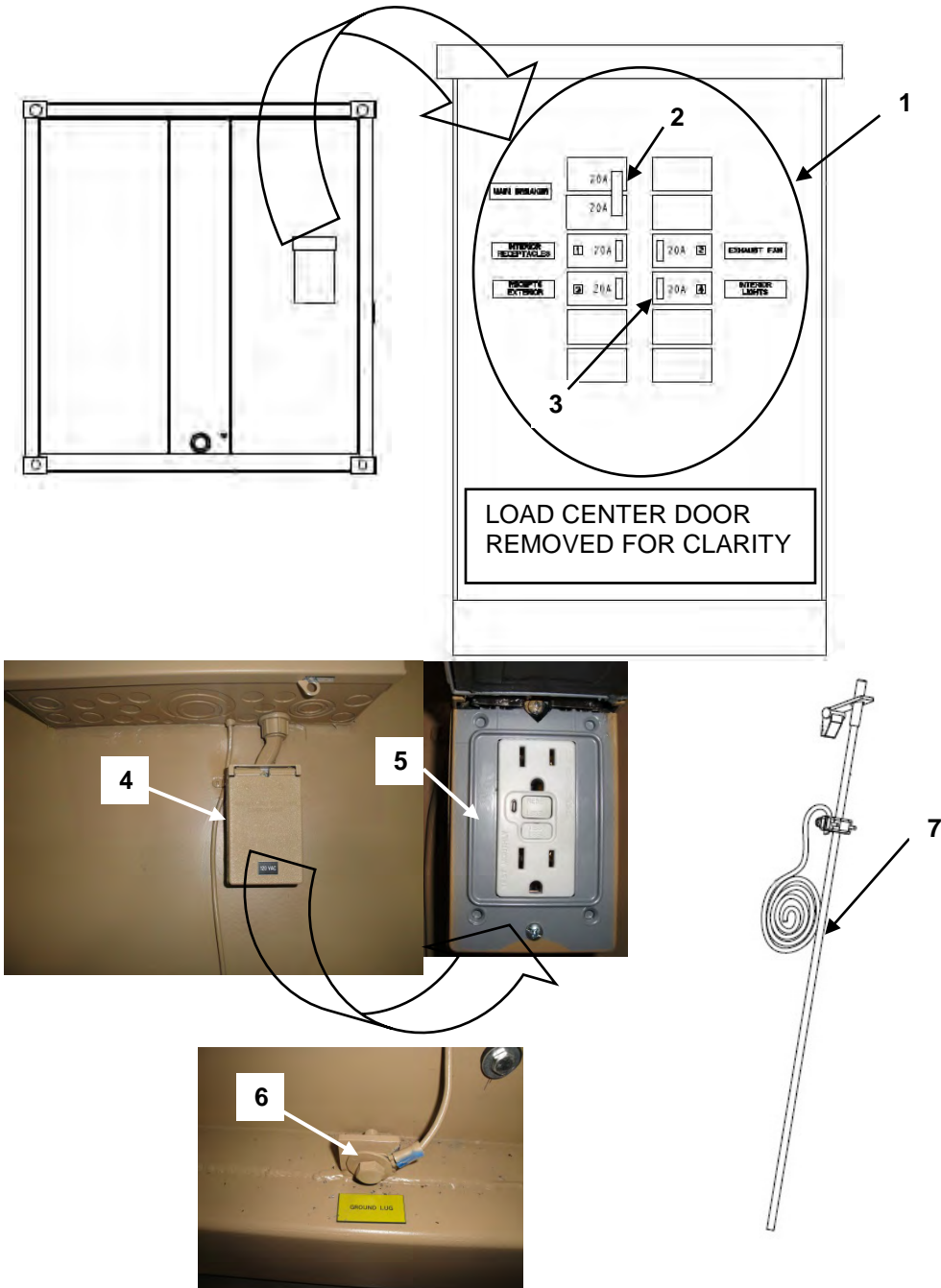

FIGURE 04 CONTAINERIZED LATRINE EXTERNAL ELECTRICAL

(1) ITEM NO.	(2) NSN	(3) CAGEC	(4) PART NUMBER	(5) DESCRIPTION AND USABLE ON CODE (UOC)	(6) QTY
				GROUP 02 FIGURE 04 CONTAINERIZED LATRINE EXTERNAL ELECTRICAL	
1	NOT ASSIGNED	1NSG3	15988511	.Load Center Kit	1
2	NOT ASSIGNED	1NSG3	72150306	..Main Circuit Breaker Duplex 20 amp	1
3	NOT ASSIGNED	1NSG3	72150204	..Circuit Breaker GFCB 20 amp	4
4	NOT ASSIGNED	1NSG3	72240201	..Weather proof Outlet Box	1
5	NOT ASSIGNED	1NSG3	72250003	..External GFCI Outlet	1
6	NOT ASSIGNED	1NSG3	18070408	..Ground Lug	1
7	NOT ASSIGNED	1NSG3	15988505	..Ground Rod Assembly	1
END OF FIGURE 04					

CONTAINERIZED LATRINE INTERIOR 6 COMPARTMENT ELECTRICAL

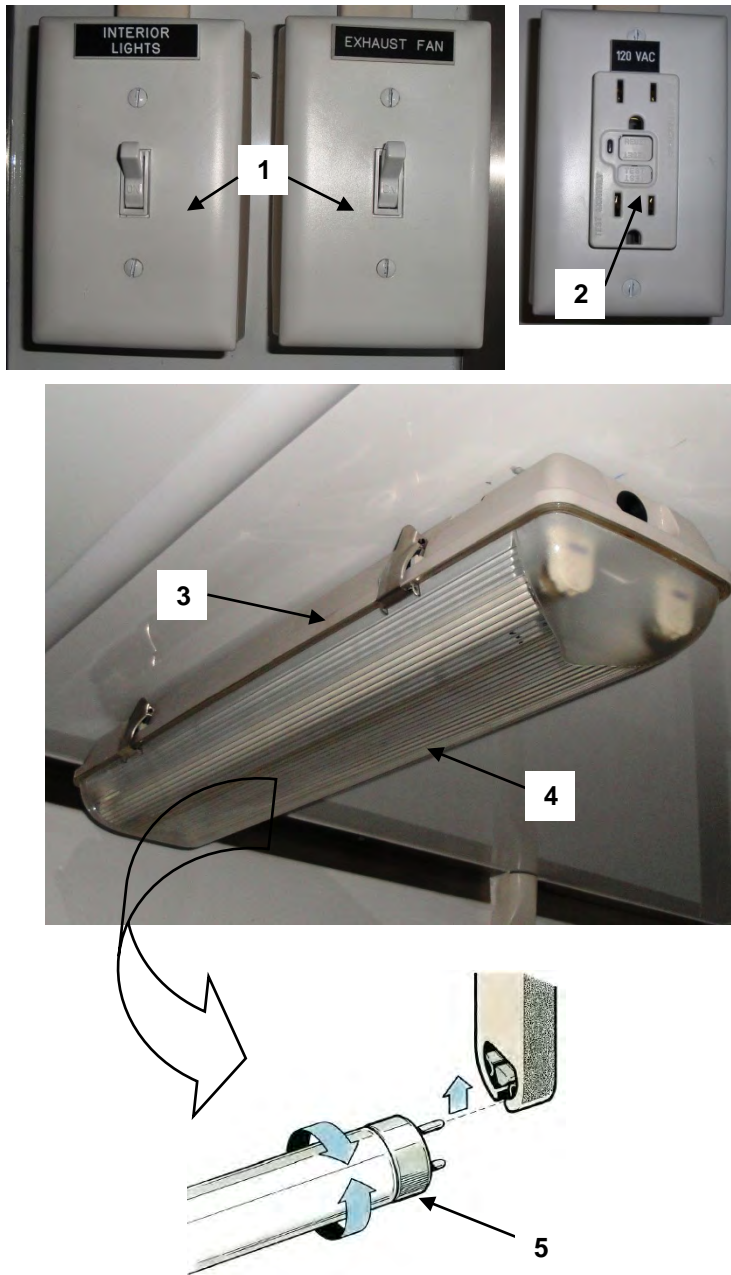

FIGURE 05 CONTAINERIZED LATRINE INTERIOR 6 COMPARTMENT ELECTRICAL

(1) ITEM NO.	(2) NSN	(3) CAGEC	(4) PART NUMBER	(5) DESCRIPTION AND USABLE ON CODE (UOC)	(6) QTY
				GROUP 0201 FIGURE 05 LATRINE INTERIOR 6 COMPARTMENT ELECTRICAL	
1	NOT ASSIGNED	1NSG3	72270201	.Light Switch	12
2	NOT ASSIGNED	1NSG3	72250003	.GFCI Outlet 20amp	6
3	NOT ASSIGNED	1NSG3	70370242	.Flourescent light fixture	6
4	NOT ASSIGNED	1NSG3	70370122	..Light fixture cover	1
5	NOT ASSIGNED	1NSG3	70380132	..Flourescent light tube	2
END OF FIGURE 05					

CONTAINERIZED LATRINE 6 COMPARTMENT INTERIOR COMPONENTS



FIGURE 06 CONTAINERIZED LATRINE 6 COMPARTMENT INTERIOR COMPONENTS

(1) ITEM NO.	(2) NSN	(3) CAGEC	(4) PART NUMBER	(5) DESCRIPTION AND USABLE ON CODE (UOC)	(6) QTY
				GROUP 03 FIGURE 06 CONTAINERIZED LATRINE 6 COMPARTMENT INTERIOR COMPONENTS	
1	NOT ASSIGNED	1NSG3	15980324	.Toilet complete Low Volume	6
2	NOT ASSIGNED	1NSG3	92400214	..Toilet Top (only)	1
3	NOT ASSIGNED	1NSG3	03583521	.Heavy Vinyl Pocket	6
4	NOT ASSIGNED	1NSG3	92020822	.Faucet-LAV 4in 2 Handle	6
5	NOT ASSIGNED	1NSG3	92010202	.Sink -SS	6
6	NOT ASSIGNED	1NSG3	87120101	.Urinal Flush Valve	6
7	NOT ASSIGNED	1NSG3	03583001	.Urinal	6
8	NOT ASSIGNED	1NSG3	91150213	.Paper Towel Dispenser	6
9	NOT ASSIGNED	1NSG3	92040513	.Soap Dispenser	6
10	NOT ASSIGNED	1NSG3	93040102	.Toilet Paper Holder	6
END OF FIGURE 06					

VANITY AND MIRRORS

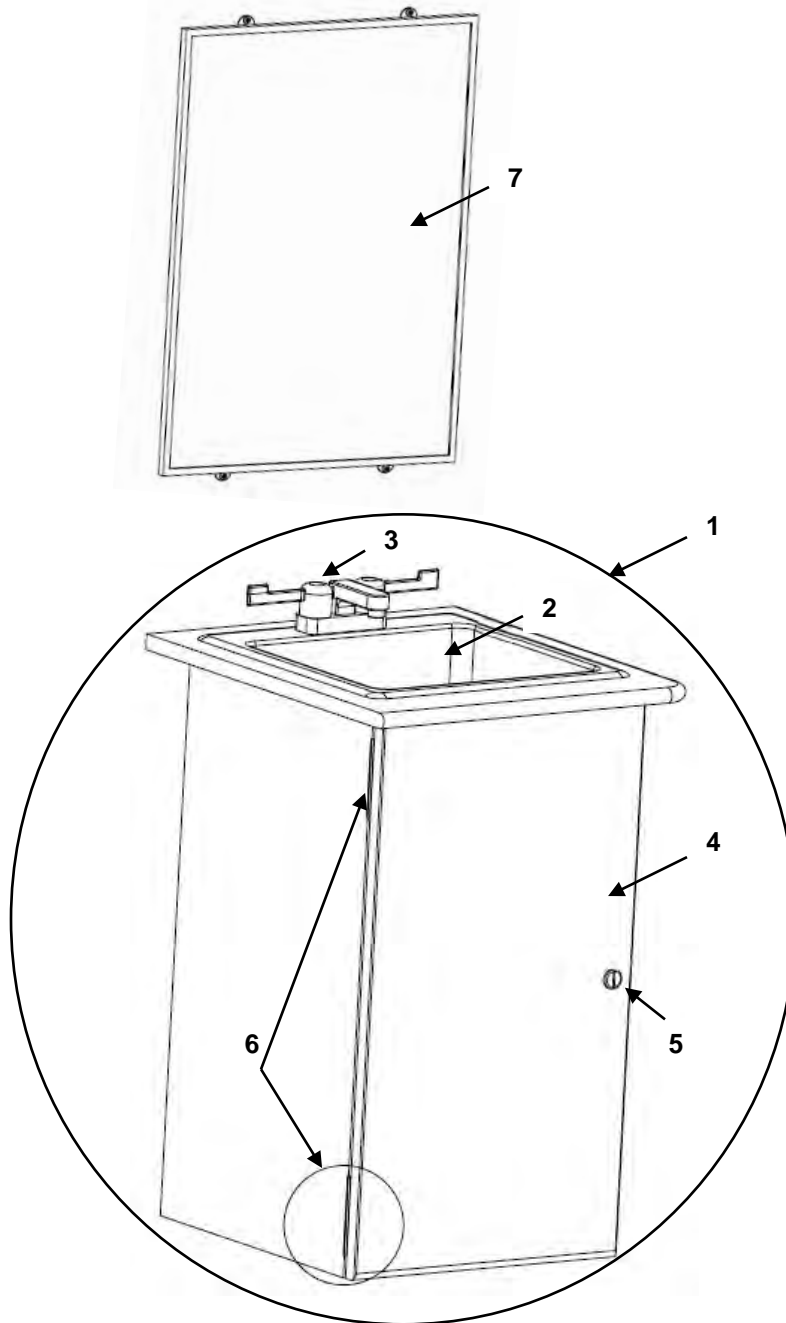

FIGURE 07 VANITY AND MIRRORS

(1) ITEM NO.	(2) NSN	(3) CAGEC	(4) PART NUMBER	(5) DESCRIPTION AND USABLE ON CODE (UOC)	(6) QTY
				GROUP 03 FIGURE 07 VANITY AND MIRRORS	
1	NOT ASSIGNED	1NSG3	15988503	.Vanity Kit	6
2	NOT ASSIGNED	1NSG3	92010202	..Sink -SS	1
3	NOT ASSIGNED	1NSG3	92020822	..Faucet-LAV 4in 2 Handle	1
4	NOT ASSIGNED	1NSG3	15988514	..Vanity Door w/Hardware	1
5	NOT ASSIGNED	1NSG3	03060005	...Lock Cylinder Flat Cam	1
6	NOT ASSIGNED	1NSG3	15988512	...Vanity Door Hinge Kit	2
7	NOT ASSIGNED	1NSG3	15988513	.Vanity Mirror Kit	6
END OF FIGURE 07					

END OF WORK PACKAGE

This page was intentionally left blank

This page was intentionally left blank

This page was intentionally left blank

Boh Environmental, LLC

MANUFACTURER'S LIMITED WARRANTY TERMS

(BOH-QF-23 Rev. 1.03)

Boh Environmental, LLC (BOH) warrants that the Products it manufactures, including the Field Pack-Up (FPU[®]) System, Containerized Mission Systems, Module Kits, and Bare Base Equipment, shall be free from defects in materials and workmanship for a period of one year from date of purchase when normally used and operated by the Customer. Unused Product containing missing or defective components shall be returned, within the warranty period, with proof of purchase, to BOH with transportation charges prepaid. BOH, at its option, shall supply a replacement item(s) or refund the purchase price of the Product. BOH shall in its sole discretion determine whether to replace the defective item(s) with identical items, or with items of identical quality and providing identical performance and functional capabilities. BOH will determine, at its sole discretion, whether or not the claim is a valid warranty item. If so, BOH will pay costs (actual transportation plus handling charge) for shipping of the replacement item, when this option is selected.

This warranty is void if Products have been damaged by the Customer as the result of improper or unreasonable use, or other causes not arising out of defects in material or workmanship. The warranty is also void if the Product has at any time been stored or used other than in accordance with the directions set out in the literature relating to the Product (e.g., user/operation manuals). BOH makes no other warranty or representation concerning the Products except that each will meet the performance specifications set forth in the literature relating to the Product. There are no further warranties, including any warranty of merchantability or fitness for a particular purpose covering the Product.

BOH will, at its option, either (1) credit user in the amount paid for any Product which does not perform to these specifications, or (2) replace such Product, provided user so notifies BOH within twelve (12) months of the Products purchase date. BOH shall not be responsible for any consequential damages to user arising as a result of such performance. The Customer will return the item at their cost, if required. Boh may elect to have its representative inspect the item to validate the claim.

Other product components included in the fabrication of items purchased under contract (e.g., air conditioners and generators) that are not manufactured by Boh Environmental are warranted by their individual manufacturer. Copies of such warranties are supplied with the finished Product or are available through BOH.

Please contact BOH for other contract specific warranty terms

This page was intentionally left blank

THE METRIC SYSTEM AND EQUIVALENTS

Linear Measure

1 centimeter = 10 millimeters = .39 inch

1 decimeter = 10 centimeters = 3.94 inches

1 meter = 10 decimeters = 39.37 inches

1 decameter = 10 meters = 32.8 feet

1 hectometer = 10 decameters = 328.08 feet

1 kilometer = 10 hectometers = 3,280.8 feet

Weights

1 centigram = 10 milligrams = .15 grain

1 decigram = 10 centigrams = 1.54 grains

1 gram = 10 decigrams = .035 ounce

1 dekagram = 10 grams = .35 ounce

1 hectogram = 10 dekagrams = 3.52 ounces

1 kilogram = 10 hectograms = 2.2 pounds

1 quintal = 100 kilograms = 220.46 pounds

1 metric ton = 10 quintals = 1.1 short tons

Liquid Measure

1 centiliter = 10 milliliters = .34 fl. ounce

1 deciliter = 10 centiliters = 3.38 fl. ounces

1 liter = 10 deciliters = 33.81 fl. ounces

1 deciliter = 10 liters = 2.64 gallons

1 hectoliter = 10 deciliters = 26.42 gallons

1 kiloliter = 10 hectoliters = 264.18 gallons

Square Measure

1 sq. centimeter = 100 sq. millimeters = .155 sq. inch

1 sq. decimeter = 100 sq. centimeters = 15.5 sq. inches

1 sq. meter (centare) = 100 sq. decimeters = 10.76 sq. feet

1 sq. decameter (are) = 100 sq. meters = 1,076.4 sq. feet

1 sq. hectometer (hectare) = 100 sq. decameters = 2.47 acres

1 sq. kilometer = 100 sq. hectometers = .386 sq. mile

Cubic Measure

1 cu. centimeter = 1000 cu. millimeters = .06 cu. inch

1 cu. decimeter = 1000 cu. centimeters = 61.02 cu. inches

1 cu. meter = 1000 cu. decimeters = 35.31 feet

Approximate Conversion Factors

To change	To	Multiply by	To change	To	Multiply by
Inches	centimeters	2.540	ounce-inches	Newton-meters	0.007062
feet	meters	0.305	centimeters	inches	0.394
yards	meters	0.914	meters	feet	3.280
miles	kilometers	1.609	meters	yards	1.094
square inches	square centimeters	6.451	kilometers	miles	0.621
square feet	square meters	0.093	square centimeters	square inches	0.155
square yards	square meters	0.836	square meters	square feet	10.764
square miles	square kilometers	2.590	square meters	square yards	1.196
acres	square hectometers	0.405	square kilometers	square miles	0.386
cubic feet	cubic meters	0.028	square hectometers	acres	2.471
cubic yards	cubic meters	0.765	cubic meters	cubic feet	35.315
fluid ounces	milliliters	29.573	cubic meters	cubic yards	1.308
pints	liters	0.473	milliliters	fluid ounces	0.034
quarts	liters	0.946	liters	pints	2.113
gallons	liters	3.785	liters	quarts	1.057
ounces	grams	28.349	liters	gallons	0.264
pounds	kilograms	0.454	grams	ounces	0.035
short tons	metric tons	0.907	kilograms	pounds	2.205
pound-feet	Newton-meters	1.356	metric tons	short tons	1.102
pound-inches	Newton -meters	0.11296			

Temperature (Exact)

$\frac{5}{9}$ (after subtracting 32) $\frac{C}{5} + 32 = F$