

**FPU® SYSTEMS OPERATION MANUAL
BOH PORTABLE DRAWER MODULE (PDM)
(INCLUDING REPAIR PARTS & SPECIAL TOOL LIST)
BOH FPU Field Pack-up Units**

**CHAPTER 2
OPERATOR INSTRUCTIONS**

THIS PAGE WAS INTENTIONALLY LEFT BLANK

**OPERATOR INSTRUCTIONS
FPU® SYSTEMS OPERATION MANUAL
BOH PORTABLE DRAWER MODULE (PDM)
(INCLUDING REPAIR PARTS & SPECIAL TOOL LIST)
BOH FPU Field Pack-up Units**

PREPARATION FOR MOVEMENT

PREPARATION FOR MOVEMENT

This work package provides step-by-step instructions for the download, set-up and moving of the BOH PDM MODULES.

WARNING



If a Module is dropped during transit movement of any kind, extreme care should be taken when opening the doors to preclude material from falling on and injuring personnel.

Site Requirements

WARNING



Modules must be operated on level ground. To maintain control, consider the ground surface conditions for adequate traction, such as mud, snow, ice and sand.

CAUTION

Flood plain conditions should be considered for PDM MODULES. Although the drawers are water tight, the operation of the Modules would be impaired in a flooding condition. If in doubt, consult the operations supervisor or commander.

PREPARING PDM MODULES FOR USE

Once downloaded from the truck, trailer or other transport vehicle, the BOH PDM MODULE is ready for immediate use in most circumstances.

WARNING



The BOH PDM MODULE is designed for a ground-based operation. Never attempt to access the BOH PDM MODULE or the drawers when the BOH PDM MODULE is on any transporting equipment, without a safe-footing established area. Always establish a safe footing operational site.

WARNING



Overhead power lines and obstructions can cause serious injury, death or damage to property. Forklift operators, truck drivers and ground guides should always clear overhead when loading or unloading the BOH PDM MODULE.

CAUTION

The stored material in any single drawer should not exceed 100 lbs.

MODULE Configuration #1 thru #4	Tare Weight	Max Gross Weight	Net (Cargo) Weight	MHE Recommended
PDM Configuration #1	1,038 lbs.	1,438 lbs.	400 lbs.	3,000 lb. forklift
PDM Configuration #2	1,421 lbs.	2,121 lbs.	700 lbs.	3,000 lb. forklift
PDM Configuration #3	1,171 lbs.	1,671 lbs.	500 lbs.	3,000 lb. forklift
PDM Configuration #4	1,240 lbs.	1,840 lbs.	600 lbs.	3,000 lb. forklift
End Of Table				

PDM Configurations

PDM CONFIGURATION #1

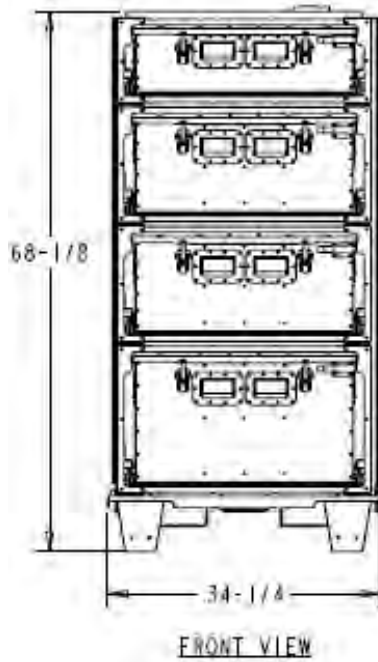

PDM CONFIGURATION #2

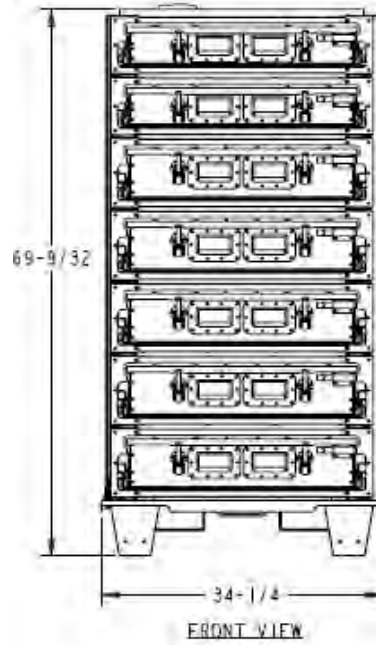

PDM CONFIGURATION #3

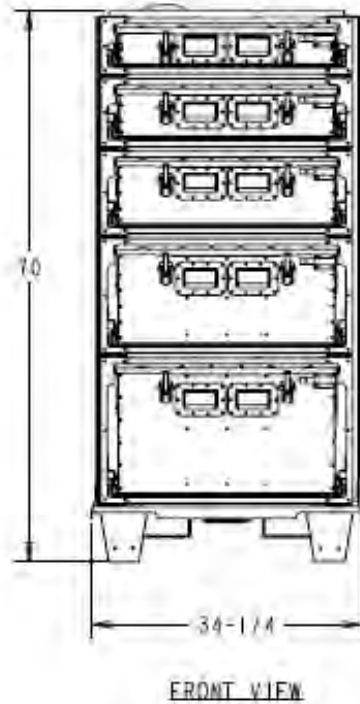

PDM CONFIGURATION #4

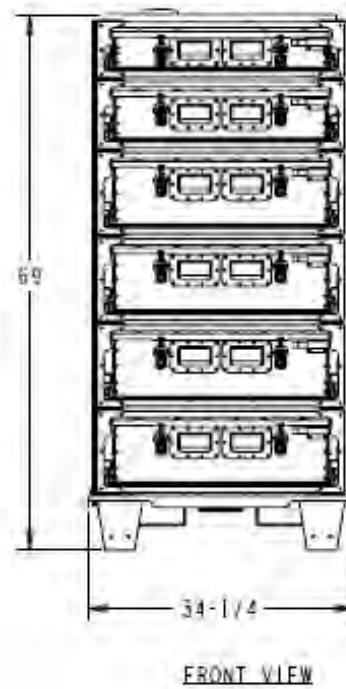

END OF WORK PACKAGE

THIS PAGE WAS INTENTIONALLY LEFT BLANK

OPERATOR INSTRUCTIONS
FPU® SYSTEMS OPERATION MANUAL
BOH PORTABLE DRAWER MODULE (PDM)
(INCLUDING REPAIR PARTS & SPECIAL TOOL LIST)
BOH FPU Field Pack-up Units

STACKING PROCEDURE

STACKING PROCEDURE

1. To assemble the PDM (1), remove the drawers and lift an empty case and tray assembly (2), with assistance of another personnel, onto the base plate (3).

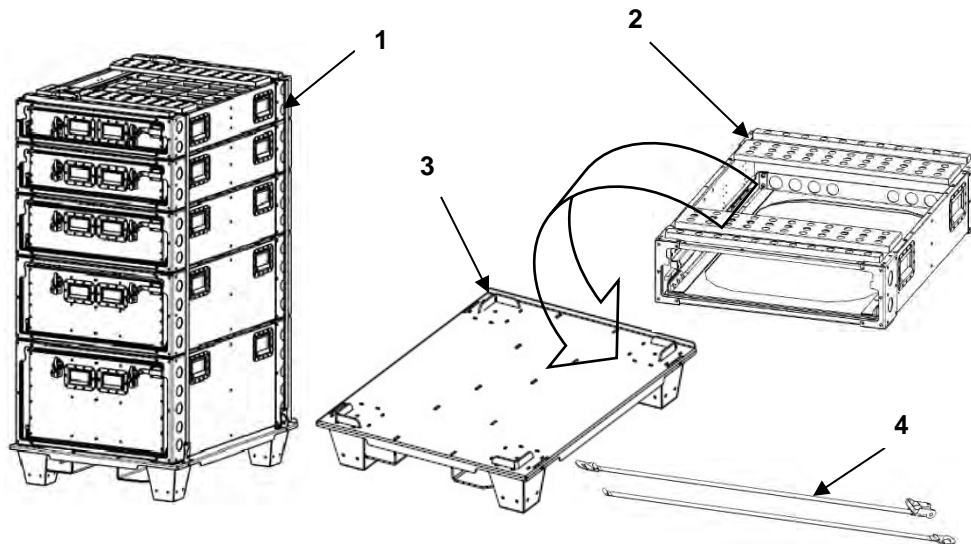

WARNING



A tilt hazard will occur when the top drawers are loaded with material and extended without any weight on the bottom drawers. Always ensure the ratchet straps (4) are tight and secure and seated in the base (3) before proceeding to the next step. Always load the PDM Module drawers from the bottom up and unload from the top down. Failure to follow this procedure may cause tipping of the module and injury to personnel.

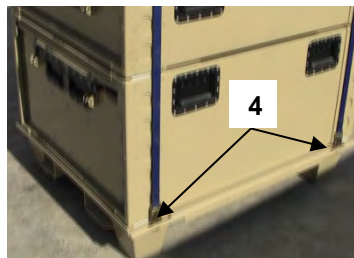

2. The case and tray assemblies (1) should be stacked with the drawers removed.
3. The PDM case and tray assemblies (1) will mate and firmly interlock when stacked, by means of the frame channels (2). Check for movement before proceeding to the next step.

WARNING



The case and tray assemblies (1) should be stacked with the drawers (3) empty and removed. It is recommended that each drawer (3) be empty before inserted into the trays, with assistance from additional personnel. A single person should not attempt to install drawers (3) without assistance.

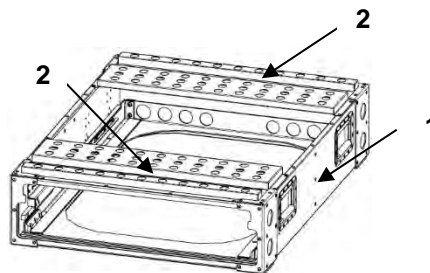
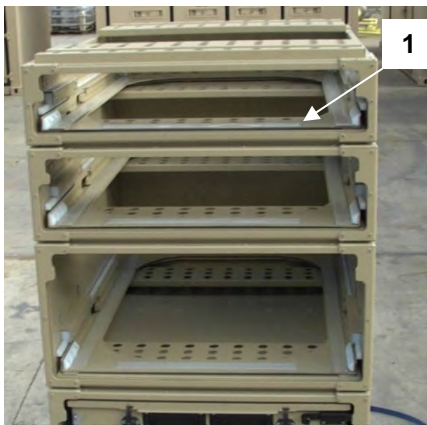

Removing the drawers

1. Pull the slam latch (4) on the left side to release the drawer (3) while pulling the drawer (3) outward.

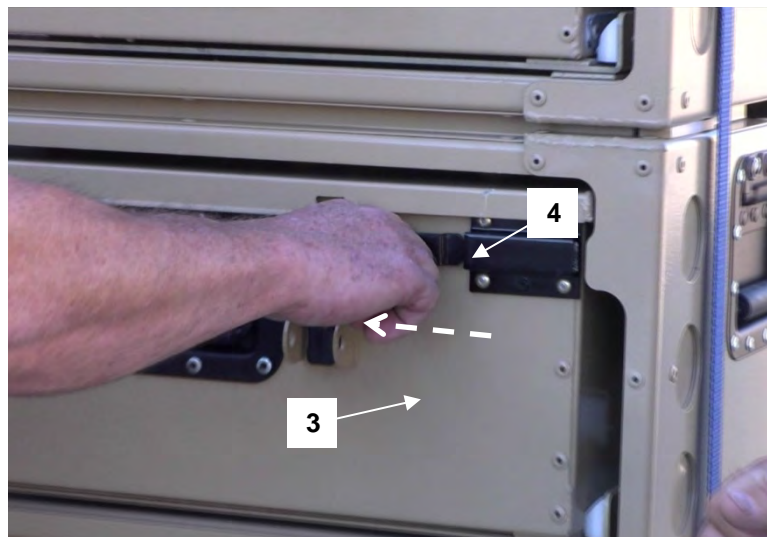

2. Remove the drawer by pulling the left and right drawer tray latches (1) outward and slide the drawer (2) and tray forward until clear of the latches (1).
3. Lift the drawer (1) from the tray.
4. Stack the drawers (2) and return the tray to the fully in position.

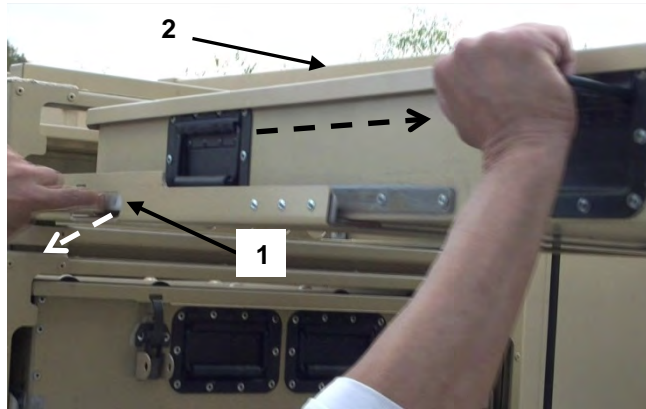

WARNING



Stack the drawers and ensure the drawer dimples (3) on the lid and bottom mate so that the drawers do not slide off each other; injury may result .

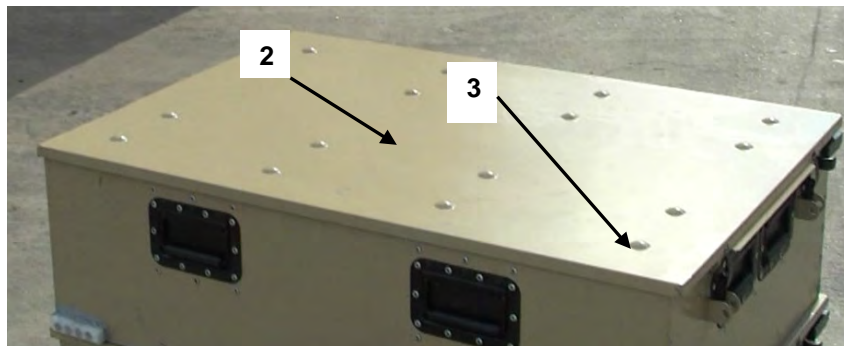

5. Once the drawers (2) have been removed from the PDM case and tray assembly, the case and trays may be arranged in the desired order.

Stacking

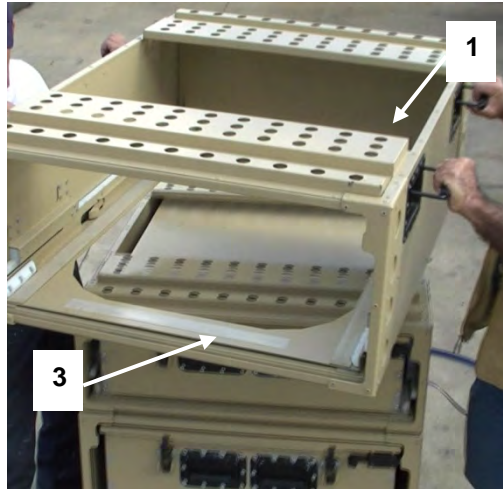

WARNING



It is recommended that the largest case and tray assemblies (1) be stacked on the bottom to create a stable PDM module. When a drawer is removed, push the tray (3) back into the case to avoid injury.

6. Once the PDM case and trays (1) have been stacked, install the front and rear ratchet straps (2) in the grooves on the top.

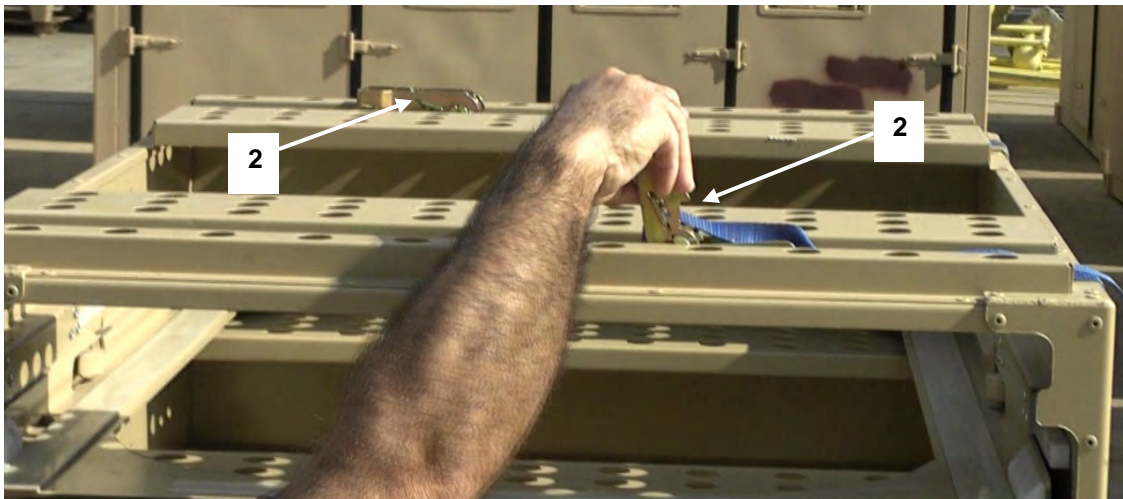

RATCHET STRAPS INSTRUCTIONS

The hook on each strap is inserted in slots (1) in the base on each side of the PDM.

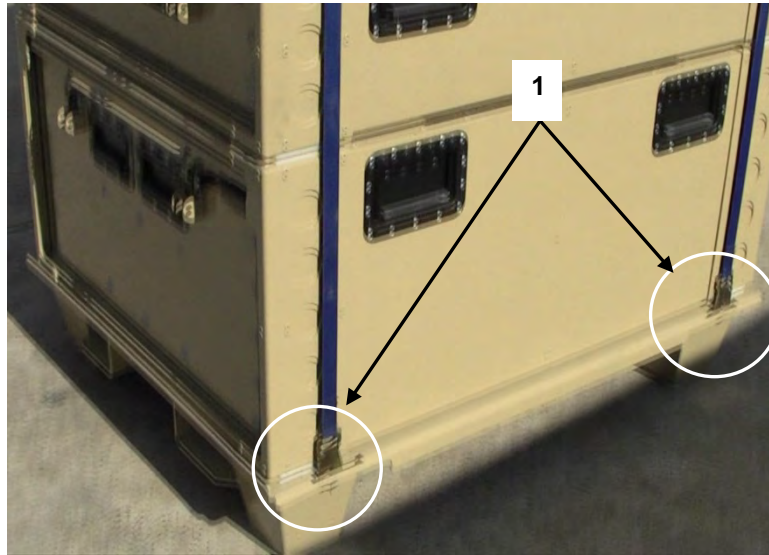

WARNING

You must check all straps for proper threading and tension. Refer to these instructions for each strap. Failure to do so will cause damage or injury.

CAUTION

Do not operate the ratchet handle (2) until all the slack is taken up or the strap will ball up and jam against the release lever. Do not overtighten the straps; this could cause damage to the straps or hooks (1).

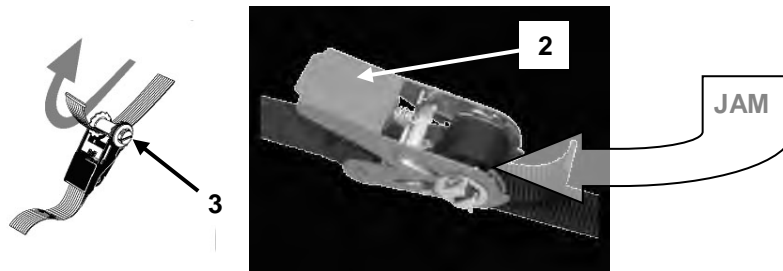

1. Feed the end of the strap through the ratchet barrel slot (3).

2. Take up the excess strap slack until the strap is snug (1).

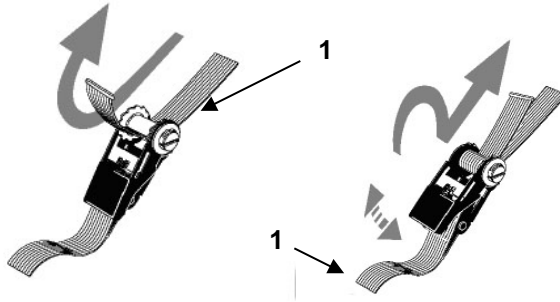

3. Tighten the strap with the ratchet handle (2) until the strap slack is firmly tight.

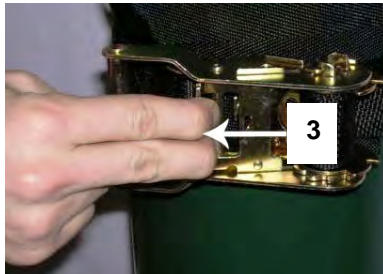
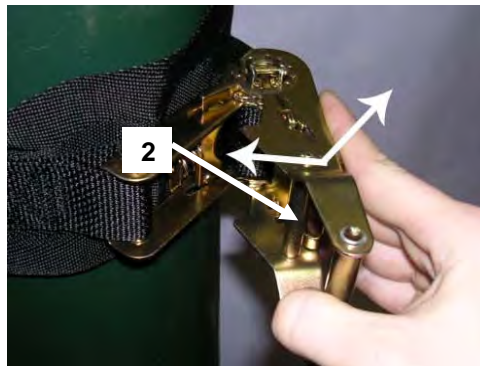

4. To adjust or release the ratchet strap, use the release lever (3) and retighten.

**OPERATOR INSTRUCTIONS
FPU® SYSTEMS OPERATION MANUAL
BOH PORTABLE DRAWER MODULE (PDM)
(INCLUDING REPAIR PARTS & SPECIAL TOOL LIST)
BOH FPU Field Pack-up Units**

TRANSPORTING THE PDM MODULE

CAUTION

The BOH PDM MODULE forklift base plate should not exceed a maximum stack height of 72". The PDM and stored material will not be readily accessible and the unit will not fit within most storage areas or the opening of the BOH FPU CARGO MODULE Systems.

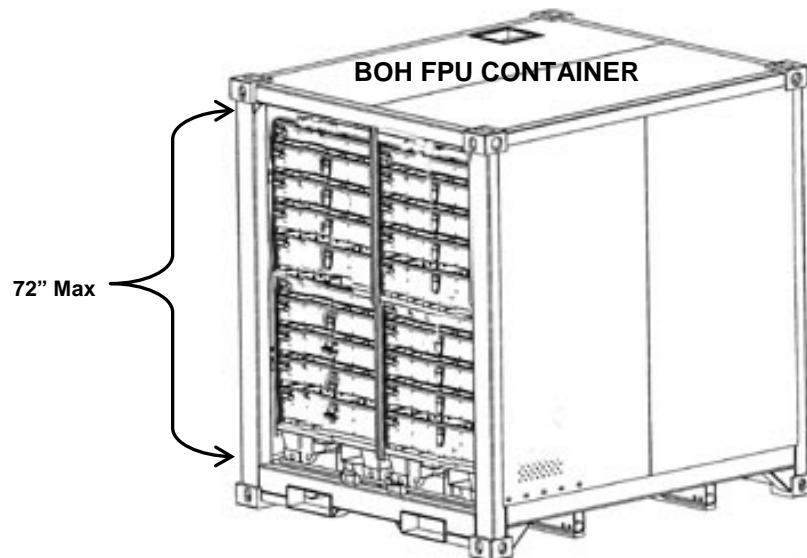

CAUTION

Allow 12" of space between the forklift carriage and the PDM MODULE when loading and unloading for greater maneuverability of the unit.

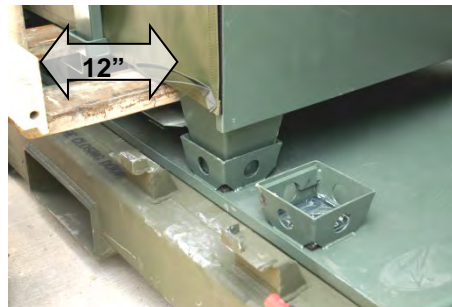

END OF WORK PACKAGE

THIS PAGE WAS INTENTIONALLY LEFT BLANK

**OPERATOR INSTRUCTIONS
FPU® SYSTEMS OPERATION MANUAL
BOH PORTABLE DRAWER MODULE (PDM)
(INCLUDING REPAIR PARTS & SPECIAL TOOL LIST)
BOH FPU Field Pack-up Units**

Operation of PDM Drawers

Removing the drawers

WARNING



This is a two-person operation. Failure to comply will cause injury.

WARNING



Always ensure the ratchet straps (1) are tight and secure and seated in the base before opening any of the drawers. Failure to comply may cause tipping of the module and injury to personnel.

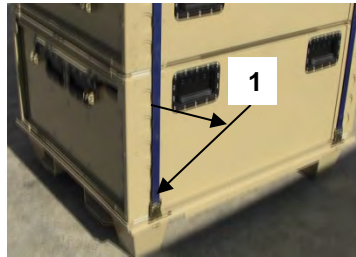

1. Pull the slam latch (2) on the left side to release the drawer while pulling the drawer (3) outward.

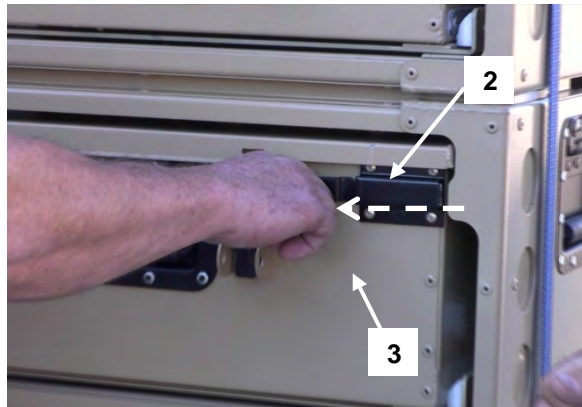

2. Remove the drawer (1) by pulling the left and right drawer tray latches (2) outward, while sliding the drawer (1) forward until clear of the latches (2).
3. With assistance, lift the drawer (1) from the tray.
4. Stack the drawers (1) and return the tray to the fully in position.

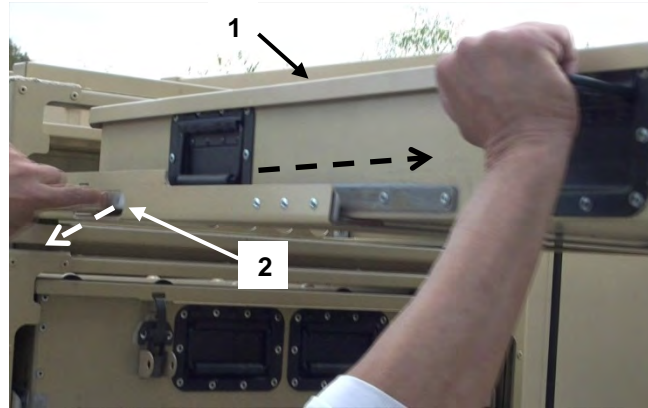

Drawer Lid

1. With the drawer pulled to the full extended position, unlatch the drawer and raise the lid (3) to the fully open position.
2. The lid (3) is supported in the open position with two gas cylinders (4).
3. The lid (3) is held in the closed position by two latches (5).
4. If arranging the drawer dividers, the cutout dividers (6) must be in place along the sides, to allow clearance for the gas cylinders (4). This clearance is required to return to the closed position without interference.
5. Close the lid (3), engage the latches (5) and return the drawer to the fully closed position.

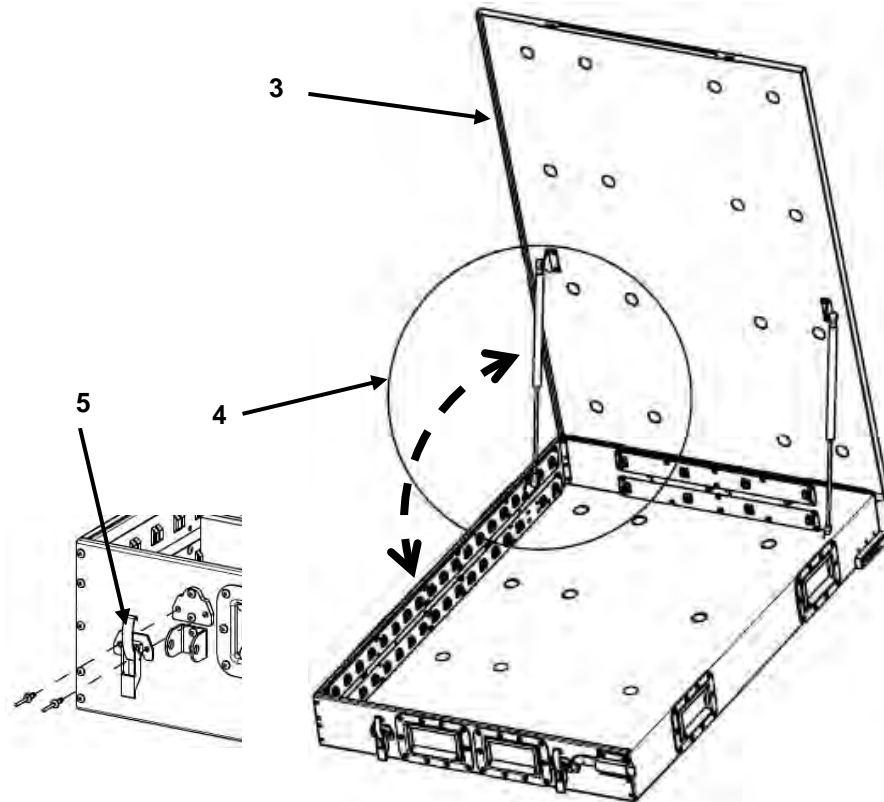
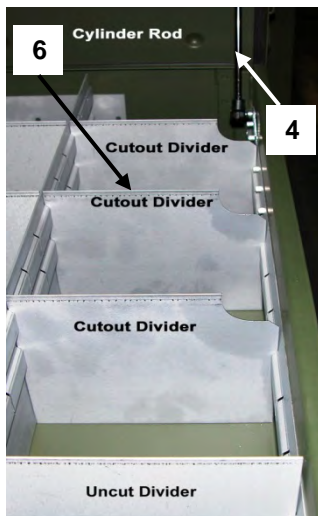

WARNING



Failure to return the tray to the full-in position creates a trip hazard; injury may result.



Unsafe Condition



Safe Condition

WARNING



Stack the drawers (1) and ensure the drawer dimples (2) on the lid and bottom mate so that the drawers (1) do not slide off; failure to do so may cause injury .

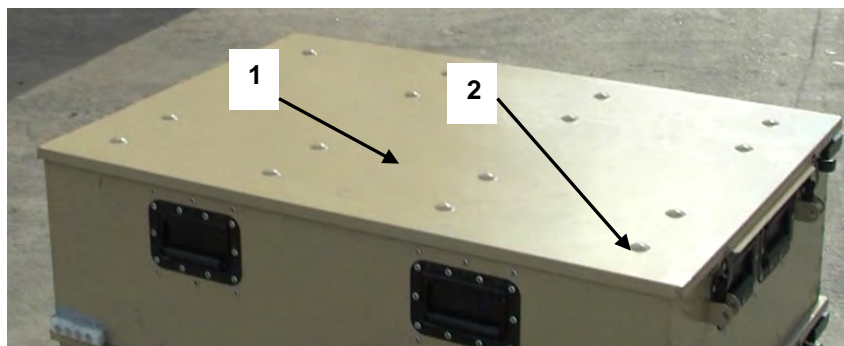

Install the Drawers

1. Pull out the tray (1) to the full out position and place the drawer (2) on the tray (1).
2. Push the tray and drawer (2) into the case assembly until the drawer slam latch (3) on the left side is engaged.

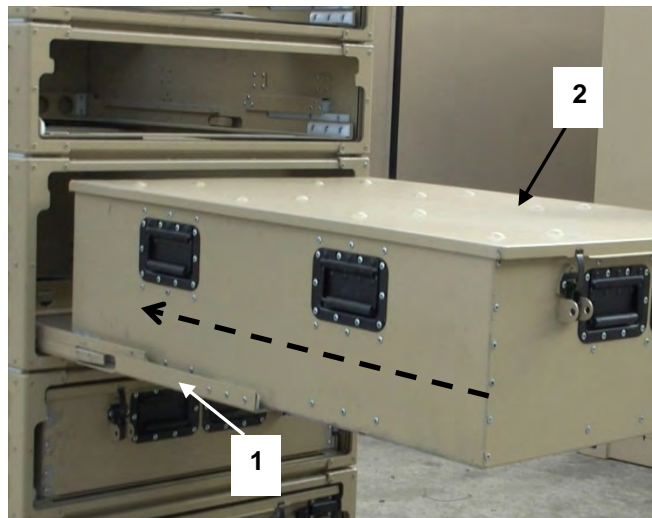
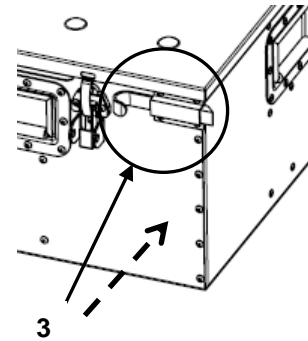
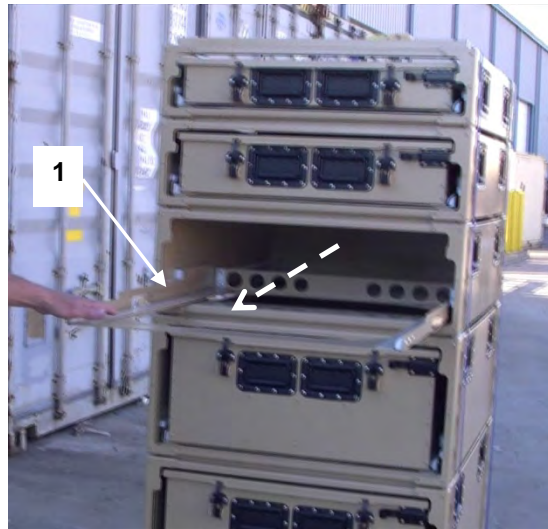

END OF WORK PACKAGE

**OPERATOR INSTRUCTIONS
FPU® SYSTEMS OPERATION MANUAL
BOH PORTABLE DRAWER MODULE (PDM)
(INCLUDING REPAIR PARTS & SPECIAL TOOL LIST)
BOH FPU Field Pack-up Units**

MODULE OPERATION UNDER UNUSUAL CONDITIONS

OPERATION UNDER UNUSUAL CONDITIONS

This work package provides instructions for the operation of the FPU modules under unusual conditions. These include adverse weather, nuclear, biological and chemical attack.

Operation in Rain and/or Mud

1. Provide an adequate drainage ditch to prevent standing water around the PDM modules.
2. Secure all accessories and containers during extremely harsh rain.

Operation in Hot Weather

WARNING



Protective gloves should be worn when handling metal parts in high temperatures. Failure to wear gloves may result in burning or blistering of the skin upon contact.

Operation in Snow, Ice, or Extreme Cold

WARNING



In extreme cold, do not touch metal parts with bare hands. Severe skin damage may result.

Fording

The PDM modules are watertight for rain and snow, but they should never be submerged in any depth of water or material damage may result. When mounted on a trailer or truck, hard-bottom water crossings should be no deeper than approximately two feet. When in doubt, refer to Unit Standard Operating Procedures.

Interim Nuclear, Biological, and Chemical (NBC) Decontamination Procedures

WARNING



The FPU modules are NOT designed to be operated in contaminated NBC environments. Do not operate the FPU in contaminated NBC environments. If possible, cease operation of the FPU modules prior to an NBC event and close all doors.

END OF WORK PACKAGE