

**FPU® SYSTEMS OPERATION MANUAL
(INCLUDING REPAIR PARTS)
EXPEDITIONARY BULK STORAGE SYSTEM (EBSS)**

**CHAPTER 4
OPERATOR MAINTENANCE INSTRUCTIONS**

This page was intentionally left blank

OPERATOR MAINTENANCE INSTRUCTIONS

FPU® SYSTEMS OPERATION MANUAL (INCLUDING REPAIR PARTS) EXPEDITIONARY BULK STORAGE SYSTEM (EBSS)

INTRODUCTION TO PREVENTATIVE MAINTENANCE CHECKS & SERVICES (PMCS)

INITIAL SETUP:

Materiel/Parts

None

Personnel Required

One

References

None

Equipment Condition

EBSS Set-up

INTRODUCTION TO PREVENTATIVE MAINTENANCE CHECKS & SERVICES (PMCS)

Preventative Maintenance Checks and Services (PMCS) are performed to keep the FPU System containers in good operating condition. These checks aid in finding, correcting, or reporting problems. Operator personnel are to perform the PMCS tasks as shown in the PMCS table.

Perform PMCS procedures each day the EBSS is in operation, using the PMCS table in (WP 0012 00). There are different intervals to perform PMCS procedures: before, during and after using the equipment, as well as weekly and monthly. Look at the table carefully to identify the required PMCS interval.

Perform all checks and services keeping in mind the following guidelines:

- Before you begin using the EBSS, perform **Before Operation PMCS** checks and services.
- While the EBSS is in use, perform **During Operation PMCS** checks and services.
- After using the EBSS, perform **After Operation PMCS** checks and services.

If you find something wrong when performing PMCS, fix it using troubleshooting and/or maintenance procedures. Pay attention to WARNING and CAUTION statements. A **WARNING** means someone could be injured or killed. A **CAUTION** means equipment could be damaged.

If tools that are required to perform PMCS are not listed in the procedures, notify your supervisor.

Inspection

Look for signs of trouble. Use your senses to feel, smell, hear, or see problems that may exist. Inspect to see if items are in good condition. Are components correctly installed and secured? Is any damage to the frame or components visible? Correct any faults or notify Maintenance.

Service

Proper service of the EBSS and components is an integral part of maintenance. Regular cleaning prevents possible problems in the future, so make it a habit to clean the EBSS and components whenever necessary.

END OF WORK PACKAGE

This page was intentionally left blank

OPERATOR MAINTENANCE INSTRUCTIONS

FPU® SYSTEMS OPERATION MANUAL
(INCLUDING REPAIR PARTS)
EXPEDITIONARY BULK STORAGE SYSTEM (EBSS)

PMCS TABLE

INITIAL SETUP:

Materiel/Parts

Rags, Water

Personnel Required

One

References

None

Equipment Condition

EBSS Set-up

Table 1 Preventative Maintenance Checks and Services for the EBSS
PMCS B (Before), D (During), A (After), W (Weekly), M (Monthly)

	B	D	A	W	M	Inspection Item and Procedure	Equipment Not Ready/Available If
1	*	*	*			Doors, Walls Check all doors and walls for cracks, dents, holes, or loose/missing hardware.	Missing doors, punctures, damage that would cause hazard or injury.
					*	Lubricate hinges, locks, as required.	Hinges and locks do not operate smoothly.
2			*	*		Exterior Check all exterior surfaces for cracks, dents that effect the operation of the EBSS or its components. Check for accumulations of dirt, debris, ice, snow, or salt. Clean as required. Check roof access steps for cracks or missing components. Replace as necessary.	Damage or malfunction that would cause the EBSS from operating properly.
3			*	*		Interior Check floor for dirt and debris. Clean with broom or rags as required. Check tiedown rings for damage.	Roof access steps cracked or missing which can cause hazard or injury. Tiedown rings damaged which can cause damage to equipment.
4			*		*	Data Plates Check plates for legibility, damage and/or missing. Clean with water and rag. Replace as needed.	ISO/CSC Safety Data plates must be replaced if missing or system will be non-deployable.

END OF WORK PACKAGE

This page was intentionally left blank

OPERATOR MAINTENANCE INSTRUCTIONS
FPU® SYSTEMS OPERATION MANUAL
(INCLUDING REPAIR PARTS)
EXPEDITIONARY BULK STORAGE SYSTEM (EBSS)

CLEANING AND LUBRICATING

INITIAL SETUP:

Materiel/Parts

Rags, Water, Detergent

Personnel Required

One

References

None

Equipment Condition

EBSS Set-up

CLEANING AND LUBRICATING

Cleaning and Lubricating of the EBSS is performed to keep the EBSS and its associated equipment in good operating condition. The cleaning and lubrication of the EBSS can be conducted along with the Preventative Maintenance Checks and Services (PMCS) procedures described in (WP 0012 00). Specific areas described below need to be cleaned after an operational event or periodically if stored/staged outside of a fixed facility to keep the container performing as designed. Cleaning also assists in maintaining the condition of the materiel stored within the system. Any damage discovered when cleaning and/or lubricating that cannot be corrected using the troubleshooting procedures described in (WP 0010 00) should be reported to maintenance for corrective action.

Table 1 Cleaning

SURFACE	OIL/GREASE	SALT/MUD/DIRT DEBRIS	RUST/CORROSION
Exterior and Interior Walls (All)	Detergent, Water, Rags	Soapy Water, Brush, Rags	Corrosion Removal Compound and Wire Brush, Dry Rag, Coat with Lube Oil or Spot Paint
Door Seals	Damp and Dry Rags	Damp and Dry Rags	N/A
EBSS Floor	Detergent, Water, Rags (Remove, clean, and replace rubber pad into footing)	Soapy Water, Brush, Rags (Remove, clean and replace rubber pad into footing)	Corrosion Removal Compound and Wire Brush, Dry Rags, Coat with Lube Oil or Spot Paint (Remove, clean, and replace rubber pad into module cradle footing)
Container Door Hinges	N/A	Brush, Rag and lubricate as needed to ensure door hinges travel freely	Corrosion Removal Compound and Wire Brush, Dry Rags and Lubricate as needed
Door Retaining Straps	Detergent, Water, Rags	Detergent, Water, Rags	N/A

Table 2 Lubrication

USAGE	FLUID or LUBRICANT	CAPACITIES	EXPECTED TEMPERATURES	INTERVAL
Door Hinges	General Purpose Lubricating Oil 10W	As Required	All Temperatures	Monthly or as required if under adverse conditions
Door Cam Locks	Molykote Multipurpose Synthetic Grease P/N 26040124	As Required	All Temperatures	Monthly or as required if under adverse conditions
Door Seals	Molykote Multipurpose Synthetic Grease P/N 26040124	As Required	All Temperatures	Monthly or as required if under adverse conditions
Folding Steps	General Purpose Lubricating Oil 10W	As Required	All Temperatures	Monthly or as required if under adverse conditions

END OF WORK PACKAGE

OPERATOR MAINTENANCE INSTRUCTIONS
FPU® SYSTEMS OPERATION MANUAL
(INCLUDING REPAIR PARTS)
EXPEDITIONARY BULK STORAGE SYSTEM (EBSS)

DOOR ASSEMBLIES

INITIAL SETUP:**Materiel/Parts**

None

Personnel Required

One

Tools

Ladder with hand rail

References

Chapter 2 WP 0006

Equipment Condition

EBSS Set-up

INSPECT

1. Open and close right door (A), left door (B), refer to chapter 2 WP 0006 to ensure proper operation and alignment.
2. Visually inspect door seals for damage.
3. Inspect for missing door straps.



WARNING

The containers must be operated on level ground and periodically be checked for shifting from a level position. Use care when opening doors or drawers; physical injury may occur. To maintain control, consider the ground surface conditions for adequate traction, such as mud, snow, ice and sand.

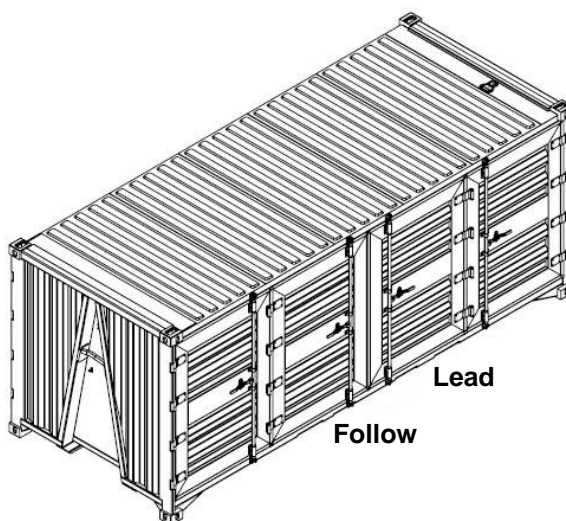

CAUTION

The right center door must lead the left center door slightly when closed to prevent damage to the door edge seals.

4. Notify maintenance of any missing or damaged seals and any problems with operation of latch, handle, or hinges for service.
5. Notify maintenance of any problems with door alignment.

END OF WORK PACKAGE

OPERATOR MAINTENANCE INSTRUCTIONS

FPU® SYSTEMS OPERATION MANUAL
(INCLUDING REPAIR PARTS)
EXPEDITIONARY BULK STORAGE SYSTEM (EBSS)

FOLDING STEPS

INITIAL SETUP:

Materiel/Parts

None

Personnel Required

One

References

Chapter 2 WP 0005 00-2 and 00-3

Equipment Condition

EBSS Set-up

INSPECT

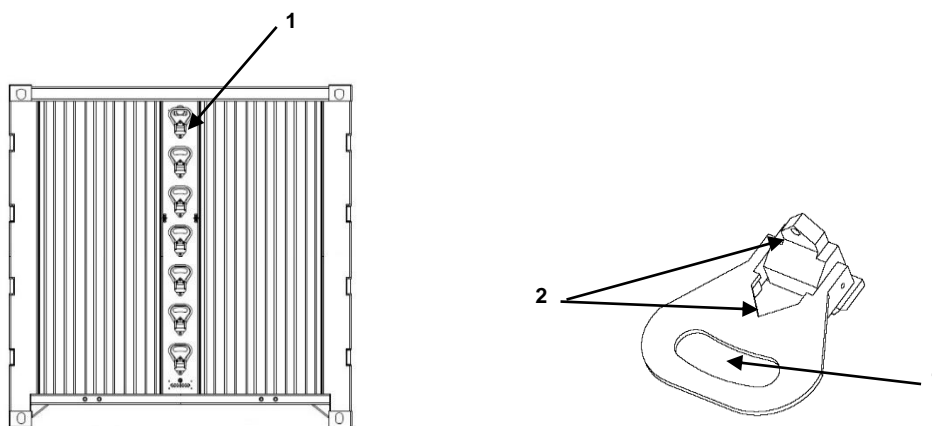

1. Raise and lower each of the steps (1) to ensure they stow and operate properly.
2. Inspect for missing ground lug (3).
3. Notify maintenance of missing, cracked, broken or poorly operating steps (1).
4. Notify maintenance of any cracked, broken or missing hardware (2).
5. Ensure that there is a ground lug (3) present.

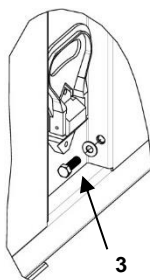

END OF WORK PACKAGE

This page was intentionally left blank